

PH 102 Exam I

INSTRUCTIONS

1. Answer all questions below. All problems have equal weight.
2. Clearly mark the answer you choose by filling in the adjacent circle.
3. There will be no partial credit given.
4. You are allowed 2 sides of a standard 8.5x11 in piece of paper with notes/formulas and a calculator.

1. Two isolated identical conducting spheres have a charge of q and $-3q$, respectively. They are connected by a conducting wire, and after equilibrium is reached, the wire is removed (such that both spheres are again isolated). What is the charge on each sphere?

- $q, -3q$
 $-q, -q$
 $0, -2q$
 $2q, -2q$

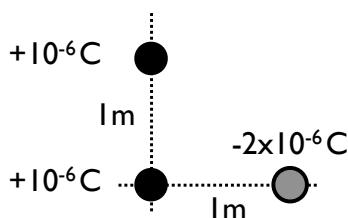

2. Two charges of $+10^{-6}\text{C}$ are separated by 1m along the vertical axis. What is the net **horizontal** force on a charge of $-2 \times 10^{-6}\text{C}$ placed one meter to the right of the lower charge?

- 0.018N
 -0.031N
 -0.024N
 -0.051N

3. Which of the following is true for the electric force and **not true** for the gravitational force?

- The force can be both attractive and repulsive between two particles.
 The force obeys the superposition principle.
 The force between two particles is inversely proportional to their separation distance squared.
 The force is conservative.

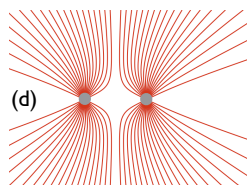
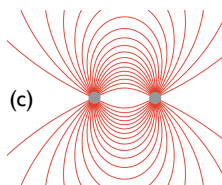
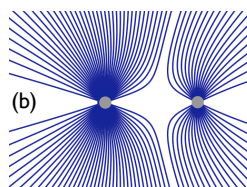
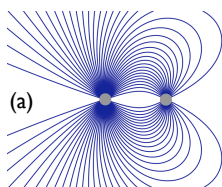

4. Which set of electric field lines could represent the electric field near two charges of the *same sign*, but *different magnitudes*?

- a
 b
 c
 d

5. A single point charge $+q$ is placed exactly at the center of a hollow conducting sphere of radius R . Before placing the point charge, the conducting sphere had zero net charge. What is the magnitude of the electric field *outside* the conducting sphere at a distance r from the center of the conducting sphere? *I.e., the electric field for $r > R$.*

- $|\vec{E}| = -\frac{k_e q}{r^2}$
 $|\vec{E}| = \frac{k_e q}{(R+r)^2}$
 $|\vec{E}| = \frac{k_e q}{R^2}$
 $|\vec{E}| = \frac{k_e q}{r^2}$

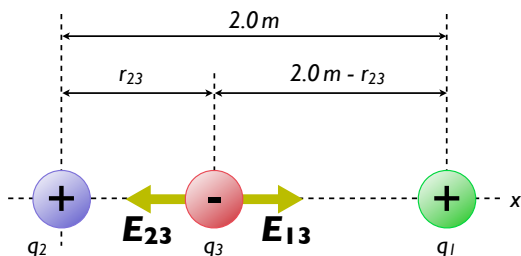

6. Three point charges lie along the x axis, as shown at left. A positive charge $q_1 = 15 \mu\text{C}$ is at $x = 2$ m, and a positive charge of $q_2 = 6 \mu\text{C}$ is at the origin. Where must a *negative* charge q_3 be placed on the x -axis **between the two positive charges** such that the resulting electric force on it is zero?

- $x = +0.77$ m
 $x = -3.44$ m
 $x = +1.34$ m
 $x = -1.44$ m

7. A proton at rest is accelerated parallel to a uniform electric field of magnitude 8.36 V/m over a distance of 1.10 m. If the electric force is the only one acting on the proton, what is its velocity in km/s after it has been accelerated over 1.10 m? *The proton mass is given at the end of the exam.*

- 30.0 km/s
 1800 km/s
 42.0 km/s
 21.0 km/s

8. It takes 3×10^6 J of energy to fully recharge a 9 V battery. How many electrons must be moved across the 9 V potential difference to fully recharge the battery?

- 1×10^{25} electrons
 2×10^{24} electrons
 4×10^{12} electrons
 8×10^{13} electrons

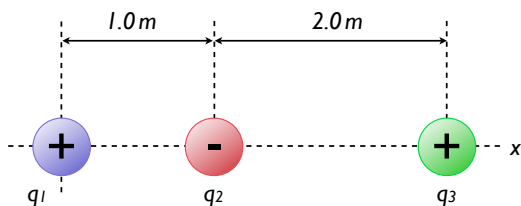

9. Three charges are positioned along the x axis, as shown at left. All three charges have the same *magnitude* of charge, $|q_1| = |q_2| = |q_3| = 10^{-9}$ C (note that q_2 is negative though). What is the total **potential energy** of this system of charges? We define potential energy zero to be all charges infinitely far apart.

- 2.3×10^{-9} J
 -6.7×10^{-10} J
 1.8×10^{-9} J
 -1.0×10^{-8} J

10. A parallel plate capacitor is shrunk by a factor of two in every dimension – the separation between the plates, as well as the plates' length and width are all two times smaller. If the original capacitance is C_0 , what is the capacitance after all dimensions are shrunk?

- $2C_0$
- $\frac{1}{2}C_0$
- $4C_0$
- $\frac{1}{4}C_0$

11. The figure at right shows the **equipotential** lines for two different configurations of two charges (the charges are the solid grey circles). Which of the following is true?

- The charges in (a) are of the same sign and magnitude, the charges in (b) are of the same sign and different magnitude.
- The charges in (a) are of opposite sign and of the same magnitude, the charges in (b) are of the opposite sign and different magnitude.
- The charges in (a) are of the same sign and magnitude, the charges in (b) are of the opposite sign and the same magnitude.
- The charges in (a) are of the opposite sign and different magnitude, the charges in (b) are of the same sign and different magnitude.

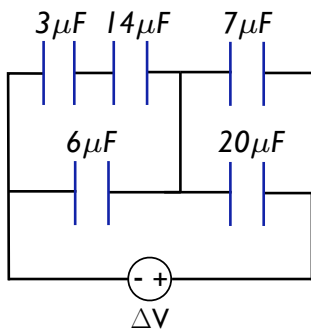
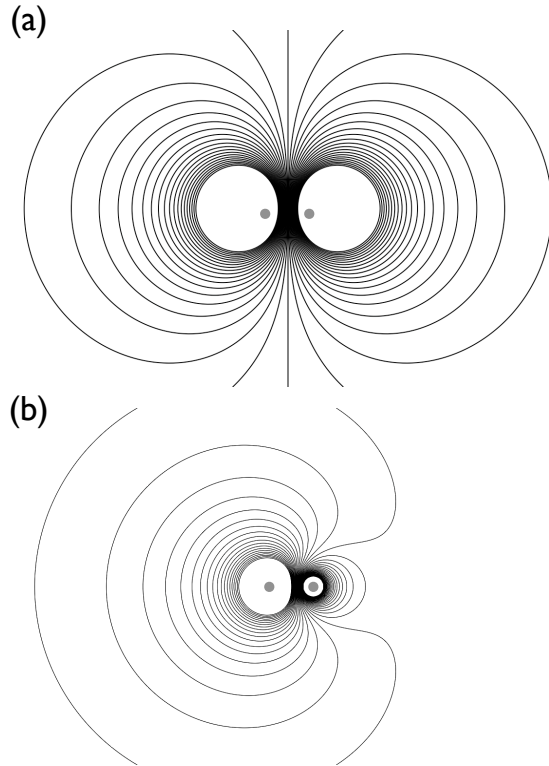

12. What is the equivalent capacitance for the five capacitors at left (approximately)?

- $6.0 \mu\text{F}$
- $29 \mu\text{F}$
- $24 \mu\text{F}$
- $1.7 \mu\text{F}$

13. If you double the current through a resistor ...

- The potential difference doubles.
- The potential difference is half as much.
- The potential difference is the same.
- None of the above.

14. If the number of carriers in a conductor n decreases by 100 times, but the carriers' drift velocity v_d increases by 5 times, by how much does its **resistance** change?

- It increases by 20 times.
- It decreases by 500 times.
- It decreases by 20 times.
- It increases by 500 times.

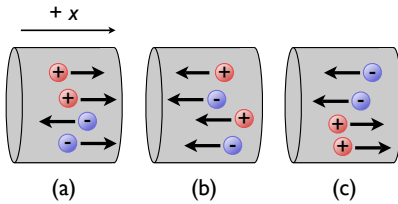

15. Rank the relative currents in figures a, b, and c from lowest to highest. Assume positive current corresponds to positive charges flowing to the right, and that all charges move at the same velocity.

- $a < b < c$
- $b < a < c$
- $c < b = a$
- $b < c < a$

16. Rank the currents at points 1, 2, 3, 4, 5, and 6 from *highest to lowest*. The two resistors are identical.

- 5, 1, 3, 2, 4, 6
- 5, 3, 1, 4, 2, 6
- 5=6, 3=4, 1=2
- 5=6, 1=2=3=4
- 1=2=3=4=5=6

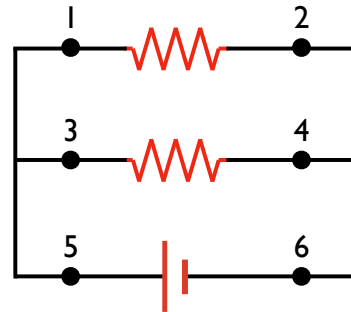

17. A flashlight uses a 1.5 V battery with a negligible internal resistance to light a bulb rated for a maximum power of 1 W. What is the maximum current through the bulb? Assume that the battery has more than enough capacity to drive this current, *i.e.*, it is ideal.

- 0.67 A
- 1.50 A
- 2.25 A
- 0.50 A

18. A 9 V battery with a $1\ \Omega$ internal resistance is connected to a $10\ \Omega$ resistor. What is the actual voltage across the $10\ \Omega$ resistor? Assume that the battery behaves as an ideal voltage source of 9 V in series with its internal resistance.

- 9.9 V
- 8.2 V
- 0.9 V
- 4.5 V

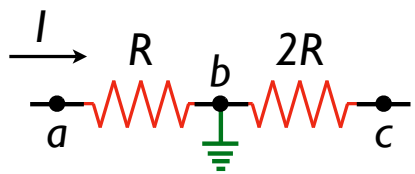

19. A current I flows through two resistors in series of values R and $2R$. The wire connecting the two resistors is connected to ground at point b . Assume that these resistors are part of a larger complete circuit, such that the current I is constant in magnitude and direction. What is the electric potential relative to ground at points a and c , V_a and V_b , respectively? *Hint: what is the potential of a ground point?*

- $V_a = -IR, V_b = -2IR$
- $V_a = 0, V_b = -3IR$
- $V_a = +IR, V_b = +2IR$
- $V_a = +IR, V_b = -2IR$

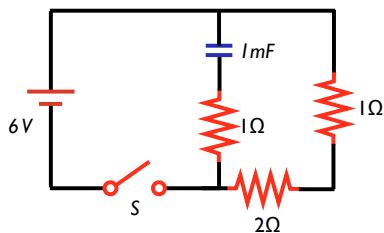

20. The switch S is suddenly closed in the circuit at left. The capacitor is uncharged before the switch is closed. After a very long time, what will be the steady-state current in the 2Ω resistor? *Hint: what is the capacitor doing after a long time?*

- 4 A
- 3 A
- 2 A
- 1 A

21. Refer to the figures at right. What happens to the reading on the ammeter when the switch S is opened? Assume the wires and switch are perfect, and have zero resistance.

- The reading goes up.
- The reading goes down.
- The reading does not change.
- More information is needed.

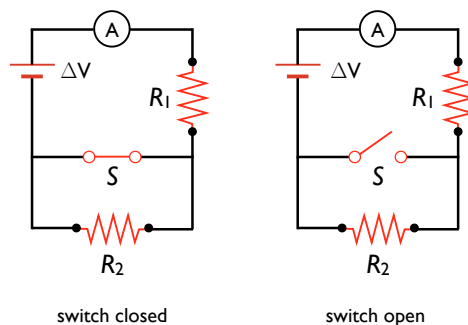

22. The basic rules we have used for analyzing circuits are: **(1)** the sum of voltage sources and drops around a closed circuit loop is zero, and **(2)** the amount of current entering a junction has to equal the amount of current leaving the junction. These rules result from two basic physical laws. What are they?

- Conservation of Energy and Charge Quantization
- Conservation of Energy and Conservation of Momentum
- Conservation of Charge and Conservation of Energy
- Coulomb's law and Conservation of Charge

23. Refer to the figure at right. Which circuit properly measures the current and voltage for the resistor? You may assume that the voltmeters and ammeters are perfect, and the battery is ideal.

- circuit (a)
- circuit (b)
- circuit (c)
- circuit (d)

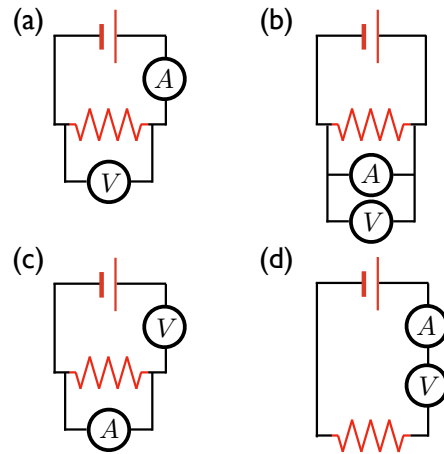

24. A potential difference of 11 V is found to produce a current of 0.45 A in a 3.8 m length of wire with a uniform radius of 3.8 mm. What is the resistivity of the wire?

- $200 \Omega \cdot \text{m}$
- $2.9 \Omega \cdot \text{m}$
- $2.0 \times 10^6 \Omega \cdot \text{m}$
- $2.9 \times 10^{-4} \Omega \cdot \text{m}$

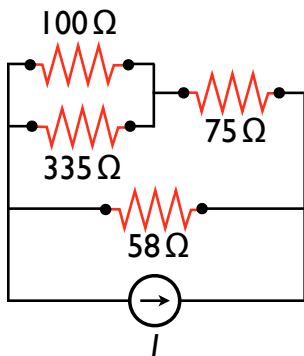

25. What is the equivalent resistance of the arrangement of resistors at left? You do not need to include the current source in your analysis

- 42Ω
- 122Ω
- 175Ω
- 31Ω

BONUS QUESTION

(worth as much as one normal question)

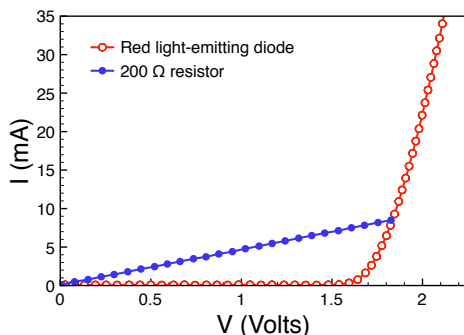

26. The figure at right shows the current-voltage relationship for a light-emitting diode (LED) and a resistor. When the voltage is 1.7 V, which has the **higher resistance**? *Hint: what does the slope of this plot mean?*

- The resistor.
- The LED.
- Cannot be determined.
- They have the same resistance.

Useful Things

Constants:

$$\begin{aligned}
 k_e &\approx 9 \times 10^9 \text{ N} \cdot \text{m}^2/\text{C}^2 \\
 e &= 1.602 \times 10^{-19} \text{ C} \\
 \epsilon_0 &= 8.85 \times 10^{12} \text{ C}^2/\text{N} \cdot \text{m}^2 \\
 k_e &= \frac{1}{4\pi\epsilon_0} \\
 m_{e^-} &= 9.11 \times 10^{-31} \text{ kg} \quad \text{Electron mass} \\
 m_{p^+} &= 1.67 \times 10^{-27} \text{ kg} \quad \text{Proton mass}
 \end{aligned}$$

Electric Force & Field

$$\begin{aligned}
 \vec{\mathbf{F}}_e &= q\vec{\mathbf{E}} \\
 \vec{\mathbf{E}} &= k_e \frac{|q|}{r^2} \\
 \Phi_E &= |\vec{\mathbf{E}}|A \cos \theta_{EA} \\
 \Phi_E &= \frac{Q_{\text{inside}}}{\epsilon_0} \\
 \Delta PE &= -W = -q|\vec{\mathbf{E}}||\Delta\vec{\mathbf{x}}| \cos \theta = -qE_x \Delta x \\
 &\quad \uparrow \text{ constant E field}
 \end{aligned}$$

Capacitors:

$$\begin{aligned}
 Q_{\text{capacitor}} &= C\Delta V \\
 C_{\text{parallel plate}} &= \frac{\epsilon_0 A}{d} \\
 E_{\text{capacitor}} &= \frac{1}{2} Q\Delta V \\
 C_{\text{eq, par}} &= C_1 + C_2 \\
 C_{\text{eq, series}} &= \frac{C_1 C_2}{C_1 + C_2} \\
 C_{\text{with dielectric}} &= \kappa C_{\text{without}}
 \end{aligned}$$

Resistors:

$$\begin{aligned}
 I_{V \text{ source}} &= \frac{\Delta V}{R + r} \\
 \Delta V_{V \text{ source}} &= \Delta V_{\text{rated}} \frac{R}{r + R} \\
 I_{I \text{ source}} &= I_{\text{rated}} \frac{r}{r + R} \\
 R_{\text{eq, series}} &= R_1 + R_2 \\
 R_{\text{eq, par}} &= \frac{R_1 R_2}{R_1 + R_2}
 \end{aligned}$$

Quadratic formula:

$$\begin{aligned}
 ax^2 + bx^2 + c &= 0 \\
 x &= \frac{-b \pm \sqrt{b^2 - 4ac}}{2a}
 \end{aligned}$$

Basic Equations:

$$\begin{aligned}
 \vec{\mathbf{F}}_{\text{net}} &= m\vec{\mathbf{a}} \quad \text{Newton's Second Law} \\
 \text{KE} &= \frac{1}{2}mv^2 \quad \text{Kinetic energy} \\
 W &= \vec{\mathbf{F}} \cdot \Delta\vec{\mathbf{x}} = |\vec{\mathbf{F}}||\Delta\vec{\mathbf{x}}| \cos \theta \\
 \Delta\text{KE} &= W = -\text{PE} \\
 \Delta\text{KE} &= \text{KE}_{\text{final}} - \text{KE}_{\text{initial}} \\
 \text{KE}_{\text{initial}} + \text{PE}_{\text{initial}} &= \text{KE}_{\text{final}} + \text{PE}_{\text{final}}
 \end{aligned}$$

Electric Potential:

$$\begin{aligned}
 \Delta V &= V_B - V_A = \frac{\Delta\text{PE}}{q} \\
 q\Delta V &= \Delta\text{PE} \\
 \Delta PE &= q\Delta V = -q|\vec{\mathbf{E}}||\Delta\vec{\mathbf{x}}| \cos \theta = -qE_x \Delta x \\
 &\quad \uparrow \text{ constant E field} \\
 V_{\text{point charge}} &= k_e \frac{q}{r} \\
 PE_{\text{pair of point charges}} &= k_e \frac{q_1 q_2}{r_{12}} \\
 PE_{\text{system}} &= \text{sum over unique pairs of charges} \\
 -W &= \Delta\text{PE} = q(V_B - V_A)
 \end{aligned}$$

Current:

$$\begin{aligned}
 I &= \frac{\Delta Q}{\Delta t} = nqAv_d \\
 J &= \frac{I}{A} = nqv_d \\
 v_d &= \frac{-e\tau}{m} E \quad \tau = \text{scattering time} \\
 \rho &= \frac{ne^2\tau}{m} \\
 \Delta V &= \frac{\rho l}{A} I = RI \\
 R &= \frac{\rho l}{A} = \frac{\Delta V}{I} \\
 \mathcal{P} &= I\Delta V
 \end{aligned}$$