

## Problem Set 5 SOLUTIONS

1. **5 points.** Are the two headlights of a car wired in series or in parallel? How can you tell?

Have you ever seen cars driving down the road with only one working headlight? If headlights were wired in series, when one light goes out, both would go out. Wiring headlights in parallel means that when one bulb goes out, the other stays lit.

2. **5 points.** What advantage might there be in using two identical resistors in parallel connected in series with another identical parallel pair, rather than just using a single resistor?

The combination we are talking about is this one:

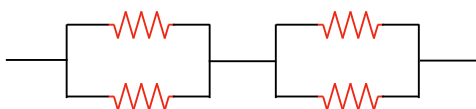

You can verify for yourself that if each individual resistor has a value  $R$ , the equivalent resistance of the arrangement above is also  $R$ . The advantage in this situation compared to using a single resistor of value  $R$  is that while the *total* power dissipation is the same, it is now divided between four resistors. This arrangement lets one use several physically smaller low power components instead of one bulky high-power component. For instance, if you only had resistors rated at 15 W, but your circuit required 30 W, one could use the arrangement above safely.

Each in this case would each have half of the total voltage (due to the series combination) and half the total current (due to the parallel combination). Since power is current times voltage, the total power in any given resistor is one quarter what it would be for a single resistor connected to the same power source.

Another advantage would be redundancy, as with the headlights in question 1 - in this arrangement, one single failure will still allow the circuit to operate. For instance, the four resistors might be electric heaters connected to a constant voltage source (like a wall socket). A single heater could fail, and if the rest of the circuit were properly designed, the remaining three would still provide  $2/3$  of the original power.

3. **15 points.** An electric heater is rated at 1500 W, a toaster at 750 W, and an electric grill at 1000 W. The three appliances are connected to a common 120 V household circuit. (a) How much current does each draw? (b) Is a circuit with a 25 A circuit breaker sufficient in this situation? Explain your answer.

The appliances must be connected in parallel, for two reasons. First, household outlets are specified to have a fixed voltage, which must mean that they must be in parallel. Second, if the appliances were in series, one could never use them individually - If they were in series, one empty outlet would make all the rest go dead. (That is related to question 1 as well).

Connecting the appliances in parallel also ensures they all have the same voltage, which is the basic idea behind all normal household wiring - keep the voltage fixed, and limit the current drawn with breakers or fuses. It has to be this way, since an empty wall outlet could not possibly have a certain current flowing out of it with nothing connected - one can never guarantee a specific current until something is connected, but one can guarantee a specific voltage between two unconnected wires.

We can calculate the current drawn by each from the power, since  $\mathcal{P} = I\Delta V$  then  $I = \mathcal{P}/\Delta V$ . Thus:

$$\begin{aligned} \text{heater: } I &= \frac{1500 \text{ W}}{120 \text{ V}} = 12.5 \text{ A} \\ \text{toaster: } I &= \frac{750 \text{ W}}{120 \text{ V}} = 6.25 \text{ A} \\ \text{grill: } I &= \frac{1000 \text{ W}}{120 \text{ V}} = 8.33 \text{ A} \end{aligned}$$

Since the appliances are in parallel, the total current drawn from the outlet is the sum of these individual currents:

$$I_{\text{total}} = 12.5 + 6.25 + 8.33 = 27.1 \text{ A} > 25 \text{ A}$$

The current drawn is greater than 25 amps, so the breaker would not be sufficient - something will have to be plugged in to another outlet, or only two of the three appliances can be run at the same time.

**4. 15 points.** A dead battery is charged by connecting it to the live battery of another car with jumper cables (see below). Determine the current in the starter and in the dead battery.

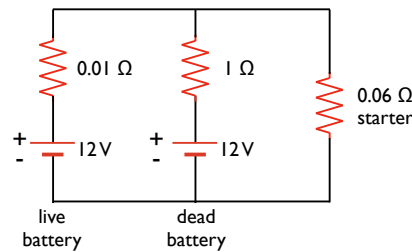

Since this circuit has several branches and multiple batteries, we cannot reduce it by using our rules of series and parallel resistors - we have to use Kirchhoff's rules. In order to do that, we first need to assign currents in each branch of the circuit. It doesn't matter what directions we choose at all, assigning directions is just to define what is, relatively speaking, positive and negative. If we choose the direction for one current incorrectly, we will get a negative number for that current to let us know. Below, we choose initial currents  $I_1$ ,  $I_2$ , and  $I_3$  in each branch of the circuit.

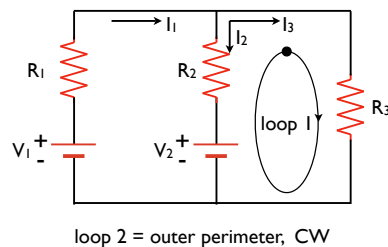

Here we have also labeled each component symbolically to make the algebra a bit easier to sort out. Note that since we have three unknowns - the three currents - so we will need three equations to solve this problem completely.

Now we are ready to apply the rules. First, the junction rule. We have only two junctions in this circuit, in the center at the top and bottom where three wires meet. The junction rule basically states that the current into a junction (or node) must equal the current out. In the case of the upper node, this means:

$$I_1 = I_2 + I_3 \tag{1}$$

You can easily verify that the lower node gives you the same equation. Next, we can apply the loop rule. There are three possible loops we can take: the rightmost one containing  $R_3$  and  $R_2$ , the leftmost one containing  $R_1$  and  $R_2$ , and the outer perimeter (containing  $R_1$  and  $R_3$ ). We only need to work through two of them - we have already one equation above, and we only need two more. Somewhat arbitrarily, we will pick the right side and perimeter loops.

First, the outer loop. Start just above the live battery  $V_1$ , and walk *clockwise* around the loop. We cross the battery from positive to negative for a *gain* in potential energy, and we cross  $R_1$  and  $R_3$  in the direction of current flow for a *loss* of potential energy. These three have to sum to zero for a closed loop:

$$V_1 - I_1 R_1 - I_3 R_3 = 0 \tag{2}$$

Next, the right-hand side loop. Again, start just above the battery ( $V_2$  this time), and walk *clockwise* around the loop. Now we cross the battery and  $R_3$  for a gain and loss of voltage, respectively, but then cross  $R_2$  in the opposite direction of the current - this gives a voltage *gain*:

$$V_2 - I_3 R_3 + I_2 R_2 = 0 \tag{3}$$

Now we have three equations and three unknowns, and we are left with the pesky problem of solving them for the three currents. There are many ways to do this, we will illustrate two of them. Before we get started, let us repeat the three questions in a more symmetric form.

$$\begin{aligned} I_1 - I_2 - I_3 &= 0 \\ R_1 I_1 + R_3 I_3 &= V_1 \\ R_2 I_2 - R_3 I_3 &= -V_2 \end{aligned}$$

The first way we can proceed is by substituting the first equation into the second:

$$\begin{aligned} V_1 &= R_1 I_1 + R_3 I_3 = R_1 (I_2 + I_3) + R_3 I_3 = R_1 I_2 + (R_1 + R_3) I_3 \\ \implies V_1 &= R_1 I_2 + (R_1 + R_3) I_3 \end{aligned}$$

Now our three equations look like this:

$$\begin{aligned} I_1 - I_2 - I_3 &= 0 \\ R_1 I_2 + (R_1 + R_3) I_3 &= V_1 \\ R_2 I_2 - R_3 I_3 &= -V_2 \end{aligned}$$

The last two equations now contain only  $I_1$  and  $I_2$ , so we can solve the third equation for  $I_2$  ...

$$I_2 = \frac{I_3 R_3 - V_2}{R_2}$$

... and plug it in to the second one:

$$V_1 = R_1 I_2 + (R_1 + R_3) I_3 = R_1 \left( \frac{I_3 R_3 - V_2}{R_2} \right) + (R_1 + R_3) I_3$$

$$V_1 + \frac{V_2 R_1}{R_2} - \left( R_1 + R_3 + \frac{R_1 R_3}{R_2} \right) I_3 = 0$$

$$I_3 = \frac{V_1 + \frac{V_2 R_1}{R_2}}{R_1 + R_3 + \frac{R_1 R_3}{R_2}}$$

$$I_3 = \frac{V_1 R_2 + V_2 R_1}{R_1 R_2 + R_2 R_3 + R_1 R_3} \approx 172 \text{ A}$$

Now that you know  $I_3$ , you can plug it in the expression for  $I_2$  above, you should find  $I_2 \approx -1.7 \text{ A}$ . Why negative? All that means is that our original guess for the direction of  $I_2$  was wrong - rather than flowing down the center wire, it actually flows up.<sup>i</sup>

What is the second way to solve this? We can start with our original equations, but in a different order:

$$I_1 - I_2 - I_3 = 0$$

$$R_2 I_2 - R_3 I_3 = -V_2$$

$$R_1 I_1 + R_3 I_3 = V_1$$

The trick we want to use is formally known as ‘Gaussian elimination,’ but it just involves adding these three equations together in different ways to eliminate terms. First, take the first equation above, multiply it by  $-R_1$ , and add it to the third:

$$\begin{array}{r} [-R_1 I_1 + R_1 I_2 + R_1 I_3] = 0 \\ + \quad R_1 I_1 + R_3 I_3 = V_1 \\ \hline \implies R_1 I_2 + (R_1 + R_3) I_3 = V_1 \end{array}$$

Now take the second equation, multiply it by  $-R_1/R_2$ , and add it to the new equation above:

$$\begin{array}{r} -\frac{R_1}{R_2} [R_2 I_2 - R_3 I_3] = -\frac{R_1}{R_2} [-V_2] \\ + \quad R_1 I_2 + (R_1 + R_3) I_3 = V_1 \\ \hline \implies \left( \frac{R_1 R_3}{R_2} + R_1 + R_3 \right) I_3 = \frac{R_1}{R_2} V_2 + V_1 \end{array}$$

Now the resulting equation has only  $I_3$  in it. Solve this for  $I_3$ , and proceed as above.

**Optional:** There is one more way to solve this set of equations using matrices and Cramer’s rule,<sup>ii</sup> if you are familiar with this technique. If you are not familiar with matrices, you can skip to the next problem - you are not required or necessarily expected to know how to do this. First, write the three equations in matrix form:

$$\begin{bmatrix} R_1 & 0 & R_3 \\ 0 & R_2 & -R_3 \\ 1 & -1 & -1 \end{bmatrix} \begin{bmatrix} I_1 \\ I_2 \\ I_3 \end{bmatrix} = \begin{bmatrix} V_1 \\ -V_2 \\ 0 \end{bmatrix}$$

$$\mathbf{aI} = \mathbf{V}$$

The matrix  $\mathbf{a}$  times the column vector  $\mathbf{I}$  gives the column vector  $\mathbf{V}$ , and we can use the determinant of the matrix  $\mathbf{a}$  with

<sup>i</sup>If you think about that, it means that we aren’t charging the battery at all, but still draining it. Hopefully the 171 A through the starter is enough to turn over the engine.

<sup>ii</sup>See ‘Cramer’s rule’ in the Wikipedia to see how this works.

Cramer's rule to find the currents. For each current, we construct a new matrix, which is the same as the matrix  $\mathbf{a}$  except that the corresponding column is replaced by the column vector  $\mathbf{V}$ . Thus, for  $I_1$ , we replace column 1 in  $\mathbf{a}$  with  $\mathbf{V}$ , and for  $I_2$ , we replace column 2 in  $\mathbf{a}$  with  $\mathbf{V}$ . We find the current then by taking the new matrix, calculating its determinant, and dividing that by the determinant of  $\mathbf{a}$ . Below, we have highlighted the columns in  $\mathbf{a}$  which have been replaced to make this more clear:

$$I_1 = \frac{\begin{vmatrix} V_1 & 0 & R_3 \\ -V_2 & R_2 & -R_3 \\ 0 & -1 & -1 \end{vmatrix}}{\det \mathbf{a}} \quad I_2 = \frac{\begin{vmatrix} R_1 & V_1 & R_3 \\ 0 & -V_2 & -R_3 \\ 1 & 0 & -1 \end{vmatrix}}{\det \mathbf{a}} \quad I_3 = \frac{\begin{vmatrix} R_1 & 0 & V_1 \\ 0 & R_2 & -V_2 \\ 1 & -1 & 0 \end{vmatrix}}{\det \mathbf{a}}$$

Now we need to calculate the determinant of each new matrix, and divide that by the determinant of  $\mathbf{a}$ .<sup>iii</sup> First, the determinant of  $\mathbf{a}$ .

$$\det a = -R_1R_2 - R_1R_3 + 0 - 0 + 0 - R_2R_3 = -(R_1R_2 + R_2R_3 + R_1R_3)$$

We can now find the currents readily from the determinants of the modified matrices above and that of  $\mathbf{a}$  we just found:

$$I_1 = \frac{-V_1R_2 - V_1R_3 + 0 - 0 + V_2R_3 - 0}{-(R_1R_2 + R_2R_3 + R_1R_3)} = \frac{V_1(R_2 + R_3) - V_2R_3}{R_1R_2 + R_2R_3 + R_1R_3} \approx 170 \text{ A}$$

$$I_2 = \frac{R_1V_2 - 0 - V_1R_3 - 0 + 0 + R_3V_2}{-(R_1R_2 + R_2R_3 + R_1R_3)} = \frac{R_3V_1 - V_2(R_1 + R_3)}{R_1R_2 + R_2R_3 + R_1R_3} \approx -1.7 \text{ A}$$

$$I_3 = \frac{0 - R_1V_2 + 0 - 0 + 0 - V_1R_2}{-(R_1R_2 + R_2R_3 + R_1R_3)} = \frac{R_1V_2 + R_2V_1}{R_1R_2 + R_2R_3 + R_1R_3} \approx 171.6 \text{ A}$$

These are the same results you would get by continuing on with either of the two previous methods. Both numerically and symbolically, we can see from the above that  $I_1 = I_2 + I_3$ :

$$I_2 + I_3 = \frac{R_3V_1 - V_2(R_1 + R_3) + R_1V_2 + R_2V_1}{R_1R_2 + R_2R_3 + R_1R_3} = \frac{V_1(R_2 + R_2) + V_2(R_1 - R_1 - R_3)}{R_1R_2 + R_2R_3 + R_1R_3} = \frac{V_1(R_2 + R_2) - V_2R_3}{R_1R_2 + R_2R_3 + R_1R_3} = I_1$$

**5. 20 points.** A group of students on spring break manages to reach a deserted island in their wrecked sailboat. They splash ashore with fuel, a European gasoline-powered 240 V generator, a box of North American 100 W, 120 V lightbulbs, a 500 W 120 V hot pot, lamp sockets, and some insulated wire. While waiting to be rescued they decide to use the generator to operate some bulbs.

(a) Draw a diagram of a circuit they can use, containing the minimum number of lightbulbs with 120 V across each bulb, and no higher output.

(b) One student catches a fish and wants to cook it in the hot pot. Draw a diagram of a circuit containing the hot pot and the minimum number of lightbulbs with 120 V across each device, and not more. Find the current in the generator and its power output.

Due to some rather savage time constraints at the moment, I have not had time to present a full solution here. Hopefully this will happen soon. Below is a sketch of the simplest configurations in each case, you should be able to verify that both work (neither power nor voltage rating is exceeded for any component), and no components could be removed.

Briefly: for the first one, you want to make sure that the bulbs each get 120 V, or half of what the generator provides. Put two in series, and they each have half the voltage. Is the power rating OK? Given a power rating and a voltage rating for the bulbs, you can calculate both the resistance and maximum allowed current. Given the resistance of the bulb, you can

<sup>iii</sup>Again, the Wikipedia entry for 'determinant' is quite instructive.

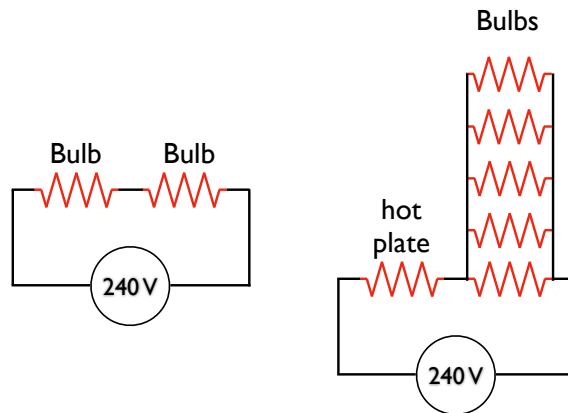

calculate the current in the left-hand diagram above, and verify that each bulb receives exactly 100 W.

For the second one, simply putting the bulb and hot pot in series is no good - they don't have the same resistance, so they won't split the voltage equally anymore. One (the bulb) will take too much voltage and bad things will happen. Thus, we need to reduce the resistance of a set of bulbs before we can put them in series with the hot pot and divide the voltage between them. We can reduce the resistance of a set of bulbs by putting them in parallel with each other. You can verify that 5 bulbs in parallel have the same resistance as the hot pot, so they will all have 120 V as will the hot pot in the right-hand configuration. Further, given the resistance of each, you can calculate the total current, total power, and current in each component and verify that nothing has exceeded its rated power.

**6. 15 points.** Two resistors  $R_1$  and  $R_2$  are in parallel with each other. Together they carry total current  $I$ . (a) Determine the current in each resistor. (b) Prove that this division of the total current  $I$  between the two resistors results in less power delivered to the combination than any other division. It is a general principle that current in a direct current circuit distributes itself so that the total power delivered to the circuit is a minimum.

First, we would like to find the current in each resistor. We will assume the setup below - two general resistors  $R_1$  and  $R_2$ , with a total current  $I$  split between them, and a voltage  $\Delta V$  on each. Remember, for parallel resistors the current is divided between them, but the voltage is the same on each.

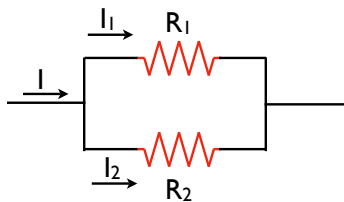

Now, we know that the voltage is the same on each resistor, and we know what each resistance is. Thus, we can already write down each current in terms of the voltage and resistances. Further, conservation of charge (or the junction rule, if you like) tells us that that  $I_1$  and  $I_2$  have to add up to the total current  $I$ .

$$\begin{aligned}
I_1 &= \frac{\Delta V}{R_1} \\
I_2 &= \frac{\Delta V}{R_2} \\
I &= I_1 + I_2
\end{aligned}$$

If we combine the first two equations with the third:

$$\begin{aligned}
I &= I_1 + I_2 = \frac{\Delta V}{R_1} + \frac{\Delta V}{R_2} = \Delta V \left( \frac{1}{R_1} + \frac{1}{R_2} \right) \\
\Rightarrow \Delta V &= I \left( \frac{1}{\frac{1}{R_1} + \frac{1}{R_2}} \right) = I \frac{R_1 R_2}{R_1 + R_2}
\end{aligned}$$

Armed with this expression for  $\Delta V$ , we can rewrite the currents  $I_1$  and  $I_2$  as fractions of the total current  $I$ :

$$\begin{aligned}
I_1 &= \frac{\Delta V}{R_1} = I \frac{R_1 R_2}{R_1 + R_2} \frac{1}{R_1} = \left[ \frac{R_2}{R_1 + R_2} \right] I \\
I_2 &= \frac{\Delta V}{R_2} = I \frac{R_1 R_2}{R_1 + R_2} \frac{1}{R_2} = \left[ \frac{R_1}{R_1 + R_2} \right] I
\end{aligned}$$

Now it is clear that each carries only a fraction of the total current, and that both currents together do indeed add to  $I$ . We could have arrived at this result much more quickly by just saying that the voltage on both resistors must be the same as on the equivalent resistor:

$$\Delta V = IR_{eq} = I \frac{R_1 R_2}{R_1 + R_2}$$

Then using our original equations for  $I_1$  and  $I_2$ , the final result follows immediately.

How do we prove that in fact this distribution of currents between the two resistors results in minimum power dissipation? We write down the total power as a function of one of the currents (say,  $I_1$ ), and find the minimum of that function. It is easier than it sounds.

First, the total power dissipated is just the power dissipated in each resistor added together. For reasons that will become clear, using the “ $I^2 R$ ” formula is most convenient. Also remember that  $I = I_1 + I_2$ , so  $I_2 = I - I_1$ .

$$\begin{aligned}
\mathcal{P} &= I_1^2 R_1 + I_2^2 R_2 \\
&= I_1^2 R_1 + (I - I_1)^2 R_2 \\
&= I_1^2 R_1 + (I^2 - 2II_1 + I_1^2) R_2 \\
&= (R_1 + R_2) I_1^2 - (2IR_2) I_1 + R_2 I^2
\end{aligned}$$

Now we have the total power as a function of the current through resistor 1. What we want to do is find the value of  $I_1$  that makes this function a minimum - that is, what fraction of the total current should resistor 1 carry such that the *overall* power dissipation is minimal? If you look carefully, this function (with  $\mathcal{P}$  on the  $y$  axis and  $I_1$  on the  $x$  axis) is just a parabola, concave upward. Where is its minimum?<sup>iv</sup>

We can find the minimum in two ways. First, by noting that it must be halfway between the roots of the parabola. Use the quadratic formula to find the two roots of the equation above, and find the midpoint between them (*i.e.*, add them together and divide by two). There are no real roots in this case, but the imaginary parts will cancel, and you will have

---

<sup>iv</sup>If you have had calculus, you can just find the derivative of  $\mathcal{P}$  with respect to  $I_1$  and set it to zero.

the value of  $I_1$  that gives the minimum power.

Another way is to complete the square<sup>v</sup> which will immediately give you the vertex, or x-coordinate of the minimum. No matter how you do it, the  $x$  coordinate of the minimum of a parabola  $ax^2+bx+c=0$  is always at  $x_{\min}=-b/2a$ . Applying that to the equation for  $\mathcal{P}$  above, we get the expression for  $I_1$  which gives minimum power dissipation in the circuit:

$$I_1 = \frac{-(-2IR_2)}{2(R_1 + R_2)} = \frac{R_2}{R_1 + R_2}I \quad \text{for minimum power dissipation}$$

This is exactly what we already found above - when the total current encounters parallel resistors, it distributes itself between the two resistors in the way that minimizes the total power dissipation. Almost like it already knows where to go!

**7. 5 points.** A fully charged capacitor stores energy  $U_0$ . How much energy remains when its charge has decreased to half its original value?

Recall from earlier in the semester that we can write the energy stored in a capacitor in terms of the total charge and capacitance. If initially our capacitor of capacitance  $C$  stores  $Q_0$  worth of charge, the energy stored is:

$$U_0 = \frac{Q_0^2}{2C}$$

If the charge decreases by two times, to  $Q_0/2$ , the new energy is:

$$U = \frac{\left(\frac{Q_0}{2}\right)^2}{2C} = \frac{Q_0^2}{4 \cdot 2C} = \frac{1}{4}U_0$$

Thus, the energy decreases by four times if the charge decreases by two times.

**8. 5 points.** A capacitor in an  $RC$  circuit is charged to 60% of its maximum value in 0.900 s. What is the time constant of the circuit?

We know that for a *charging*  $RC$  circuit, the amount of charge on the capacitor as a function of time can be written thusly:

$$q_C(t) = q_0 \left(1 - e^{-\frac{t}{\tau}}\right)$$

Here  $\tau = RC$  is the time constant of the circuit, and  $q_0$  is the charge on the capacitor when it is fully charged. We know that after 0.900 s that the charge is  $0.6q_0$  - sixty percent of the full charge. All we have to do is plug in what we know, and solve for  $\tau$ :

$$\begin{aligned} q_C(0.900 \text{ s}) &= 0.6q_0 = q_0 \left(1 - e^{-\frac{0.900 \text{ s}}{\tau}}\right) \\ 0.6 &= 1 - e^{-\frac{0.900 \text{ s}}{\tau}} \\ e^{-\frac{0.900 \text{ s}}{\tau}} &= 0.4 \\ -\frac{0.900 \text{ s}}{\tau} &= \ln 0.4 \\ \tau &= \frac{-0.900 \text{ s}}{\ln 0.4} \approx 0.982 \text{ s} \end{aligned}$$

**9. 10 points.** A capacitor of value  $C$  is discharged through a resistor of value  $R$ . **(a)** After how many time constants is the charge on the capacitor one fourth of its initial value? **(b)** After how many time constants is the *energy* at one fourth of its initial value?

---

<sup>v</sup><http://www.intmath.com/Quadratic-equations/4.Graph-quadratic-function.php>



Our capacitor is decreasing in charge here, and therefore by definition discharging. For a discharging capacitor in an  $RC$  circuit, we could write the charge on the capacitor as follows:

$$q_C(t) = q_0 e^{-\frac{t}{\tau}}$$

Here the symbols have the same meanings as in the previous problem. We know that after a certain number of time constants, we have one fourth the charge, that is,  $q_C(t) = \frac{1}{4}q_0$  for some time  $t$  we are supposed to determine. What does we mean by ‘how many time constants?’ That is just the time divided by the time constant,  $t/\tau$ , so we have to solve the equation above for that ratio, given our condition of one quarter charge.

$$\begin{aligned} q_C(t) &= \frac{1}{4}q_0 = q_0 e^{-\frac{t}{\tau}} \\ \frac{1}{4} &= e^{-\frac{t}{\tau}} \\ \ln \frac{1}{4} &= -\frac{t}{\tau} \\ \frac{t}{\tau} &= -\ln \frac{1}{4} = \ln 4 = 2 \ln 2 \approx 1.39 \end{aligned}$$

So it takes about 1.39 time constants for *any* particular  $RC$  circuit to lose a quarter of its charge. How about the energy? When the capacitor is full, and has a charge  $q_0$ , its energy is  $U_0 = q_0^2/2C$ . While the capacitor is charging or discharging, we just need to alter this formula to account for the changing amount of charge - we put in  $q_C(t)$  instead of  $q_0$ :

$$U(t) = \frac{[q_C(t)]^2}{2C} = \frac{q_0^2 e^{-\frac{2t}{\tau}}}{2C} = U_0 e^{-\frac{2t}{\tau}}$$

Remember that when you square something raised to a power, you just double the power. This means that the energy decreases exponentially during the discharge, just like the charge does, but at twice the rate. Again, this is just our usual formula for energy stored in a capacitor, all we have done is taken into account that the charge varies with time. Now we want to know for what ratio of  $t/\tau$  - how many time constants later - the energy is a quarter of its original value. This condition mathematically is  $U(t) = \frac{1}{4}U_0$ , which we can plug into our equation above:

$$\begin{aligned} U(t) &= \frac{1}{4}U_0 = U_0 e^{-\frac{2t}{\tau}} \\ \frac{1}{4} &= e^{-\frac{2t}{\tau}} \\ \ln \frac{1}{4} &= -\frac{2t}{\tau} \\ \frac{t}{\tau} &= -\frac{1}{2} \ln \frac{1}{4} = \frac{1}{2} \ln 4 = \ln 2 \approx 0.69 \end{aligned}$$

As we noted above, the energy decreases at a rate twice as fast as the charge, since energy is proportional to the *square* of the charge - this is how exponential functions work.

**10. 5 points.** Two resistors connected in series have an equivalent resistance of  $690 \Omega$ . When they are connected in parallel, their equivalent resistance is  $150 \Omega$ . Find the resistance of each resistor.

When we combine two resistors in series, they simply add to form a equivalent resistor. In parallel, they add inversely. This implies two equations:

$$\begin{aligned} R_1 + R_2 &= 690 \\ \frac{1}{R_1} + \frac{1}{R_2} &= \frac{1}{150} \end{aligned}$$

It is more convenient if we rearrange the second one (find a common denominator for the left-hand side and invert) to look like this:

$$\frac{R_1 R_2}{R_1 + R_2} = 150$$

Now, plug the first one in to the second and massage it a bit:

$$\begin{aligned} \frac{R_1 R_2}{R_1 + R_2} &= \frac{R_1 R_2}{690} = 150 \\ R_1 R_2 &= 150 \cdot 690 \end{aligned}$$

We can use our first equation a second time, noting that  $R_2 = 690 - R_1$ :

$$\begin{aligned} R_1 R_2 &= R_1 (690 - R_1) = 690R_1 - R_1^2 = 150 \cdot 690 \\ \implies R_1^2 - 690R_1 + 150 \cdot 690 &= 0 \end{aligned}$$

Now we have a quadratic that we can solve for  $R_1$ .

$$\begin{aligned} R_1 &= \frac{-(-690) \pm \sqrt{(-690)^2 - 4 \cdot 1 \cdot (150 \cdot 690)}}{2} \\ &= \frac{690 \pm \sqrt{690^2 - 600 \cdot 690}}{2} \\ &= \frac{690 \pm 690 \sqrt{1 - \frac{600}{690}}}{2} \\ &= 345 \left[ 1 \pm \sqrt{1 - \frac{600}{690}} \right] \\ &= 345 \left[ 1 \pm \sqrt{1 - \frac{20}{23}} \right] \\ &\approx 220.4, 469.6 \end{aligned}$$

Now we have two solutions for  $R_1$ . What is that? No worries. Since we labeled  $R_1$  and  $R_2$  arbitrarily, and our equations are completely symmetric with regard to either, we have actually just found *both*  $R_1$  and  $R_2$ . Try plugging them both in to the first equation, and you will see that we really only have one complete solution:

$$\begin{aligned} R_2 &= 690 - R_1 = 690 - 220.4 = 469.6 && \text{1st solution} \\ R_2 &= 690 - R_1 = 690 - 469.6 = 220.4 && \text{2nd solution} \end{aligned}$$

Thus, our two resistors have to be  $496.6 \Omega$  and  $220.4 \Omega$ .