

# A crash-course in transistor circuits

Patrick R. LeClair

July 19, 2011

## Contents

<b>1</b>	<b>Transistors</b>	<b>1</b>
1.1	Basic characteristics . . . . .	1
1.2	Notation . . . . .	2
1.3	Modeling transistor behavior . . . . .	3
1.4	Simple view: consider gain . . . . .	4
1.5	Simplest view: forget gain . . . . .	6
<b>2</b>	<b>Typical transistor circuits</b>	<b>6</b>
2.1	Switch . . . . .	6
2.2	Current source . . . . .	8

## 1 Transistors

The transistor is our first example of an “active” component which can produce an output signal with more power than its input signal. This does not violate conservation of energy, the additional power simply comes from the transistor’s power supply, the main point is that the transistor has a sort of *feedback* which will allow it to effectively add power to a given signal. It is in fact not really the power gain that we are most interested in, but this feedback property, the thing which makes a transistor an “active” component.

### 1.1 Basic characteristics

We will not dwell on how one makes a transistor, or much of the theory behind their operation. We wish only to have basic operation knowledge of how to use them. With that in mind, we should first spell out the basic properties of a transistor. A transistor is essentially a valve in the simplest sense (not a pump). It does not *force* current to flow, it rather permits it to flow to a controllable degree while the rest of the circuit surrounding the transistor tries to force current through it.

A transistor has three terminals (rather than two like a resistor or capacitor), labeled the *emitter*, the *base*, and the *collector*. Roughly speaking, the collector “collects” power from the power source, delivering it to the emitter terminal which “emits” current. The base is the control terminal: applying a voltage to the base can either open or close the connection between the collector and emitter, modulating the current flow. In terms of a (rough) hydrodynamic analogy, the collector corresponds to a pressurized water source, the emitter the drain, and the base a valve to control the flow rate.

A crucial aspect is that this valve is *sensitive* - very small currents into the base can open and close the valve to allow much larger currents to flow between collector and emitter. In this way, amplification of power (normally called “gain”) can be achieved - an input signal to the base can produce a much larger signal at the emitter.

## 1.2 Notation

In the sort of circuits we will discuss, all potential differences are measured relative to the circuit’s ground point, which defines  $V = 0$ . Thus, it is enough to refer to the potential  $V$  at any point in the circuit, knowing that  $V$  is specified relative to ground. Subscripts on voltages refer to the transistor terminals:

$$V_e = \text{emitter voltage relative to ground} \quad (1)$$

$$V_b = \text{base voltage relative to ground} \quad (2)$$

$$V_c = \text{collector voltage relative to ground} \quad (3)$$

The same is done for currents, where the convention is that positive currents flow toward lower potential (i.e., closer to ground):

$$I_e = \text{current into/out of emitter} \quad (4)$$

$$I_b = \text{current into/out of base} \quad (5)$$

$$I_c = \text{current into/out of base} \quad (6)$$

Two non-identical subscripts are used to refer to potential differences in shorthand, for example:

$$V_{bc} \equiv V_b - V_c = \text{base-collector potential difference} \quad (7)$$

$$V_{ce} \equiv V_c - V_e = \text{collector-emitter potential difference} \quad (8)$$

$$V_{be} \equiv V_b - V_e = \text{base-emitter potential difference} \quad (9)$$

Two identical subscripts are shorthand for a power supply voltage being fed in (usually to the collector):

$$V_{cc} = \text{collector supply voltage} \quad (10)$$

### 1.3 Modeling transistor behavior

Transistor comes in two flavors, *npn* and *pnp*. We will focus on the *npn* variety, but in most cases *pnp* transistors behave the same way, but with opposite polarity. Their circuit symbols are drawn like this:

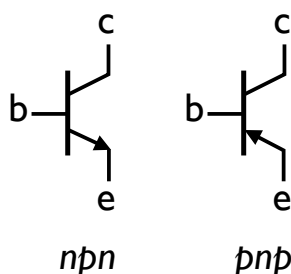

From this point on, we will worry only about *npn* transistors. Transistors of the *npn* type follow four general rules, which we will simplify even further to come up with a rough working description of transistor circuits.

1. The collector potential is higher than the emitter potential,  $V_c > V_e$ .
2. The base-emitter and base-collector circuits look like diodes. Normally, the base-emitter diode is conducting, but the base-collector diode is reverse-biased.

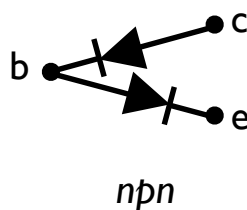

3. There are maximum values of  $I_c$ ,  $I_b$ , and  $V_{ce}$  that, if exceeded, will usually destroy the transistor. Additionally, there are other limits such as power dissipation ( $I_c V_{ce}$ ),  $V_{be}$ , temperature, etc., that must be managed for proper function of your circuit.
4. If the preceding rules are obeyed, the collector current  $I_c$  is roughly proportional to the base current  $I_b$ :

$$I_c \approx \beta I_b \quad (11)$$

where  $\beta$ , the current gain, is typically around 100.

It is the current gain  $\beta$  that allows a small current into the base connection to produce a large current at the collector and emitter. As a bit of warning, we never simply rely on the current gain  $\beta$ . It is generally quite variable, even for transistors of the same type and model, and thus only approximately specified. Our circuit designs will never rely on  $\beta$  having a particular value, as it would make them unpredictable (and therefore bad).

Point 2 is extremely important for understanding where current flows in a transistor circuit. It also allows us a simple way to test if a transistor is good. For small applied voltages to only two terminals,

- The base-emitter (be) connections should behave like a diode and conduct one way only.
- The base-collector (bc) connections should behave like a diode and conduct one way only.
- The collector-emitter (ce) connections should not conduct either way.

The last characteristic is true because if the base has zero potential, the “valve” between collector and emitter is closed. Or, if the base is unconnected, then  $I_b=0$ , and thus  $I_c=0$  (eq. 11) no matter what potential is applied between collector and emitter.

Points 1 and 4 are the keys to designing some simple transistor circuits, and they can be put a bit more succinctly:

1.  $V_c$  is greater than  $V_e$  by at least a few tenths of a volt (so current flows from  $c$  to  $e$ )
2. The surrounding circuit made such that  $V_b$  is about 0.6 V higher than  $V_e$ , i.e.,  $V_b - V_e \approx 0.6$ .

We shall proceed with two views of transistor operation: one simple, the other even simpler.

#### 1.4 Simple view: consider gain

In the simple view, we look at the transistor as a current amplifier or a current-controlled valve, and explicitly make use of the fact that the collector current is equal to the base current times the gain,  $I_c = \beta I_b$ . Looking at the three terminals of the transistor, we can apply conservation of charge (current).

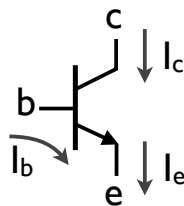

Flowing in to the transistor we have  $I_c + I_b$ , which must equal  $I_e$ :

$$I_e = I_c + I_b = \beta I_b + I_b = (1 + \beta) I_b \quad (12)$$

Thus, the current flowing out of the emitter terminal is a factor  $1+\beta$  larger than the control current flowing into the base. This allows us to take a small current input at the base and produce a large current output, *but at essentially the same voltage*. The “extra” current gained comes from the power supply. This lets us make a device known as a *follower*:

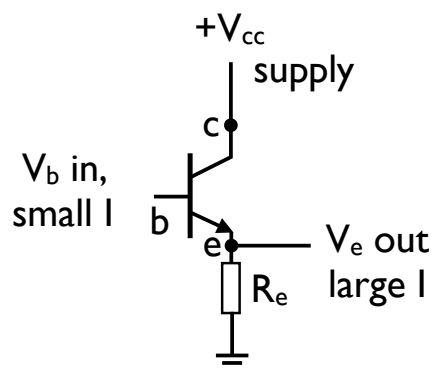

It is called a *follower* because the emitter output voltage ( $V_e$ ) follows the input base voltage ( $V_b$ ) (i.e., they vary in the same way), but the output has a much larger current. Recall that our simplified rules stated that  $V_b - V_e \approx 0.6\text{ V}$ , so the emitter voltage will do whatever the base voltage does, just  $0.6\text{ V}$  lower. A small voltage at the base  $V_b$  produces only a small current  $I_b$ , meaning the input has a relatively large resistance. The current flowing out of the emitter, and thus through the load  $R_e$  is much larger:  $I_e = (1 + \beta)I_b$  (keep in mind that the  $V_e$  output voltage is a voltmeter connection, it draws no current). We’ve taken an input signal with a given voltage and small current (low power) and transformed it into an output signal with similar voltage and much more current (high power) – a simple amplifier of sorts.

If we think of this in terms of resistance, the follower has another function. The emitter output has a current larger by a factor  $1+\beta$ , but the emitter voltage is roughly the same as the base voltage. Almost the same voltage, higher current, this means a relatively low resistance. This is one of the main functions of a follower: the output *voltage* is nearly the same as the input voltage, but the *current* is much higher, and the *resistance* much lower. This is another one of the main functions of a follower, transforming the output circuit from high to low resistance, important when connecting different circuits together.

## 1.5 Simplest view: forget gain

The preceding is a very useful circuit, but the design could be clearer yet. If we only want to worry about making rough “skeleton” circuits, figuring we can flesh them out and fancy them up later on, we can simplify the transistor rules even further. We forget about gain entirely, and just focus on two points:

1. call  $V_{be} = V_b - V_e = 0.6 \text{ V}$ , and design the surrounding circuit to make this true
2. call  $I_c = I_e$

The second point is clearer if we remember  $I_e = I_c + I_b$  based on conservation of charge. If we presume the base current to be much smaller than  $I_e$  or  $I_c$  (it is at least a factor  $\beta \sim 100$  lower than  $I_e$ ) and neglect it, then  $I_e \approx I_c$ . Now look at our follower circuit above again.

Let’s say the base voltage changes by some amount  $\Delta V_b$ . Since the emitter voltage is  $V_e = V_b - 0.6$ , its change is the same:  $\Delta V_e = \Delta V_b$ . The resistor  $R_e$  then sees a voltage change of  $\Delta V_e$ , since it is connected between emitter and ground, and this produces a current change in the resistor of

$$\Delta I_e = \frac{\Delta V_e}{R_e} = \frac{\Delta V_b}{R_e} \quad (13)$$

The emitter current is dictated by the choice of the value of  $R_e$  and the voltage change at the base. So what? Compare this with the current change at the base itself, a factor  $1 + \beta$  smaller:

$$\Delta I_b = \frac{\Delta I_e}{1 + \beta} = \frac{\Delta V_b}{R(1 + \beta)} \quad (14)$$

Thus the follower gives us the same change in voltage at the emitter that was applied to the base, but with a much larger current. Let’s say we want to have  $I_e = 1 \text{ mA}$  through the resistor  $R_e = 1 \text{ k}\Omega$ . This means we need an emitter voltage of  $V_e = I_e R_e = 1 \text{ V}$ . That means the base has to have a voltage  $0.6 \text{ V}$  higher, or  $V_b = 1.6 \text{ V}$ . This is accomplished by making a connection to the supply voltage  $V_{cc}$  through resistors, but more on that below.

## 2 Typical transistor circuits

### 2.1 Switch

Let’s make a somewhat more practical circuit. Consider the diagram below, and let’s say the load is a light bulb. What does this circuit do? Let’s follow the rules. When the mechanical switch is open, there is no base current. No base current means no emitter current and no collector current, since  $I_c = \beta I_b$  and  $I_c \approx I_e$ . That means no current through the light bulb, it stays dark.

Once we close the switch, we now have a base current, since the base is connected to the  $10 \text{ V}$  supply. The emitter is connected to ground, meaning  $V_e = 0$ , so that means the base rises to

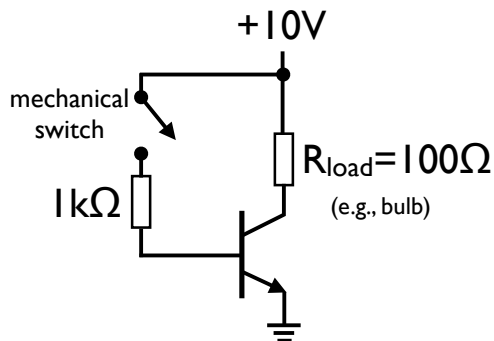

$V_b = V_e + 0.6 = 0.6$ . If the supply is at 10 V above ground and the base only 0.6 V above ground, the other 9.4 V must be on the 1 k $\Omega$  resistor.<sup>i</sup> The current in the 1 k $\Omega$  resistor is the same as the base current, since it is in series with the base, and it must be  $I_b = 9.4 \text{ V}/1 \text{ k}\Omega = 9.4 \text{ mA}$ . If the gain of our transistor is  $\beta = 100$ , the collector current (also the current through the bulb) must be  $I_c = \beta I_b = 940 \text{ mA}$ . The bulb lights up.

Unfortunately, this is wrong – at least the current is. The bulb will light up, but we have violated one of our transistor rules, that the collector voltage must be higher than the emitter voltage. The collector voltage will be 10 V minus the potential drop on the load resistor of 100  $\Omega$ . If the collector current is 940 mA, this is  $V_c = 10 - (0.94 \text{ A})(100 \Omega) \approx -84 \text{ V}$ . First, this is a bit silly since the potential difference on the resistor is larger than the supply voltage, which can't happen. Second, this makes the collector voltage lower than the emitter voltage, violating one of our main rules of transistor behavior. A transistor cannot pull the collector voltage below the emitter voltage. With the emitter grounded, that means that the collector can have at *maximum* a 10 V potential relative to the supply, giving the load resistor a 10 V potential difference.

What will really happen in this case? Closing the switch biases the base above ground (positively), which opens our valve from collector to emitter. This allows the supply to send as much current as it can through the bulb, with its entire 10 V across the bulb, and it lights up with a current of  $I_c = 10 \text{ V}/100 \Omega = 0.1 \text{ A}$ . Once the supply has dropped 10 V across the resistor, nothing further can happen - the collector will be at zero volts then, and can go no lower. We have *saturated* the transistor by bringing the collector as close to the emitter as it can go, sourcing maximum current to the bulb.

More generally, what we just made is a transistor switch – closing the mechanical switch to bias the base allows the source to apply full power to the bulb. Rather than using a mechanical switch to bias the base, we could imagine that the base voltage is produced as the output of some sensor (say, a photoresistor or microphone) which will cause the bulb to light up as an indicator when the

<sup>i</sup>Use conservation of energy: walking from the 10 V source to ground via the base, the sum of the voltage gains and losses must equal what you started with, 10 V.

sensor sees a large enough stimulus.

## 2.2 Current source

In intro physics, we tell you all about voltage sources, and note that they are easily made with electrochemical cells (i.e., batteries). You never hear how to make a *current* source. Why? Because a current source means a constant rate of charge flow, implying that the source must adjust its power, depending on what it is connected to, to ensure a certain flow of charge. A voltage source just needs to ensure a potential difference, which can occur even without anything connected. A current source is thus an *active* device which requires a bit of feedback, a task for which our transistor is ideally suited.

Let's say we want to create a 1 mA current source for driving a load of unspecified resistance (say, an LED). We can't do it with a battery, since we'd have to know the resistance to ensure a certain current. The simple circuit below does the job:

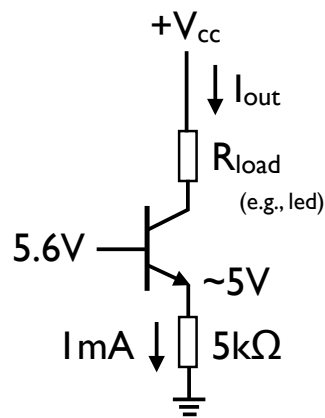

The idea is like this: fix the base voltage  $V_b$ . That fixes the emitter voltage  $V_e$ . The emitter voltage can then source a known current by connecting a known resistance between it and ground. Since the collector and emitter currents must be (approximately) the same, this fixes the collector current, so we just have to connect our load device between the collector and supply and we're done!

Let's fix the base voltage at  $V_b = 5.6\text{ V}$ . That makes the emitter voltage  $V_e \approx V_b - 0.6 = 5.0\text{ V}$ . With 5 V at the emitter, a  $5\text{ k}\Omega$  resistor connected between emitter and ground produces a current of  $I_e = 5\text{ V}/5\text{ k}\Omega = 1\text{ mA}$ . Since  $I_c \approx I_e$ , that means that whatever is connected between the supply voltage and the collector (within reason) receives a current of  $I_c = 1\text{ mA}$  from the supply. The only questions to resolve are how to set the base and emitter voltages?

Say we have  $V_{cc} = 10\text{ V}$  to be concrete. We can use series resistors - a voltage divider - to set the base voltage at the desired 5.6 V.



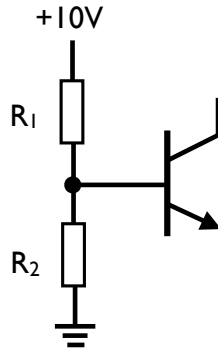

We connect the base to the 10 V supply through resistor  $R_1$ , and the base to ground through resistor  $R_2$ . The voltage at the base will be the same as the potential difference across resistor  $R_2$ . Using the rules for series resistors,

$$V_b = V_{R2} = \frac{R_2}{R_1 + R_2} V_{\text{supply}} = 5.6 \text{ V} \quad (15)$$

We can solve this for the ratio  $R_1/R_2$ , and we find

$$\frac{R_1}{R_2} = \frac{V_{\text{supply}}}{V_b} - 1 = \frac{10}{5.6} - 1 \approx 0.8 \quad (16)$$

Thus, choosing a ratio of 0.8 for the two resistors sets the desired base voltage, which in turn sets the emitter voltage and the emitter and collector currents. We don't want much current flowing through the base, so we should choose large resistors ( $\sim 100 \text{ k}\Omega$  range); picking  $R_1 = 120 \text{ k}\Omega$  and  $R_2 = 150 \text{ k}\Omega$  does the job well enough. Now we can draw the full current source circuit.

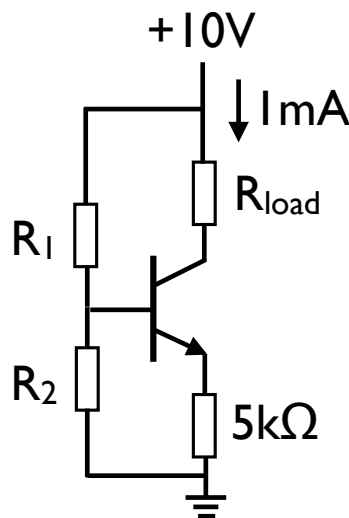

This is a perfectly reasonable 1 mA current source, taking as much power as required from the 10 V source to maintain 1 mA (or until we reach the supply's or transistor's limits . . . remember we cannot drop more than 10 V across the load resistor and keep the collector above 0 V).

### 2.2.1 Variant: automatic night light

Our next circuit is an automatic night light. We want an LED to light up whenever the ambient light level is too low. A photoresistor will help, it has a resistance in the dark of  $\sim 50\text{ k}\Omega$ , and only a few  $\text{k}\Omega$  under bright illumination. In general, its resistance follows a power-law dependence as a function of the incident light intensity, but the main point is that it has a low resistance when in bright light, and a very high resistance in the dark. The idea, then, is that we can use our previous current source skeleton circuit to power the LED, but use a current through the photoresistor to set the base voltage - high resistance (dark) gives a high base voltage, opening the collector-emitter connection and lighting the bulb, low resistance (light) gives a near-zero base voltage, closing the collector-emitter connection and turning off the LED. The circuit below accomplishes this, a sort of hybrid of our transistor switch and current source circuits.

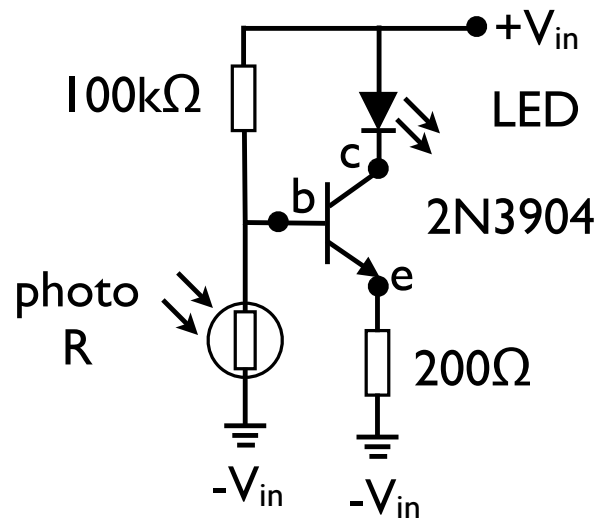

Before calculating anything, let's think qualitatively about this circuit. The  $100\text{ k}\Omega$  and photoresistor make a voltage divider from the supply. If the photoresistor is lit, it has a low resistance, and the  $100\text{ k}\Omega$  eats up most of the supply voltage. That means the voltage at the base is low, the base current is tiny, and so are the emitter and collector currents. The collector-emitter channel is closed, and the LED is dark. If the photoresistor is dark, it has a resistance comparable to the  $100\text{ k}\Omega$ , so it will take a significant fraction of the supply voltage. That means the base has a significant voltage on it, producing a large emitter and collector current, and the LED lights. The collector-emitter channel is opened by putting a voltage on the base, which we achieved by darkening the photoresistor with a current running through it. Setting the value of the resistor at

100 k $\Omega$  sets the illumination threshold for turning on the LED, so one might be even more clever by making it adjustable over some range.

How about some specifics? In this case, we presume the voltage input  $V_{in}$  is about 3.5 V, roughly 2 C cell batteries in series. We want the base to be near zero voltage when the photoresistor is dark, so we make it a part of a voltage divider for the base. The 100 k $\Omega$  resistor is chosen to match the photoresistor's dark resistance; if it is a bit lower, the light turns on when it is even darker, if it is a bit smaller, the light turns on at a bit higher illumination threshold. Why? When the photoresistor is in moderate darkness, its resistance is  $\sim 50$  k $\Omega$ , so it takes a proportion  $50/(50+100)=0.33$  of the supply voltage and the 100 k $\Omega$  resistor the other 0.66. That makes the base voltage about 1.16 V, and thus the emitter voltage only about 1 V. That means we have 1 V across the 200  $\Omega$  emitter resistor, so the emitter and collector currents are  $I_e \approx I_c \approx 5$  mA, plenty to light up the LED.

Once the photoresistor is illuminated, its resistance is only a few k $\Omega$ , let's say 2 k $\Omega$  for the sake of argument. That means the voltage drop on the photoresistor, the base voltage, is only  $2/(2+100) \approx 0.02$  of the supply voltage, or about 0.07 V. That means essentially no base current, so no emitter or collector current, and the LED doesn't light. Even more to the point, we've saturated the transistor again - the emitter should be 0.6 V lower than the 0.07 V base voltage, but it can't be - that would violate our rule that  $V_b - V_e \approx 0.6$ , and anyway the emitter is fixed at ground and can't go negative. The emitter will stay at ground ( $V_e = 0$ ), and it means the base is insufficiently biased, so the collector-emitter channel remains closed, and the LED stays dark.